



Provides the perfect balance of performance and versatility for commercial and residential routes.

- Base body weight of 17,100 pounds and industry leading payload capacity.
- With arms rated to lift 10,000 pounds and top carrying capacity, this truck is light weight and tough.
- Hydraulics mounted on the side of the body rather than the headframe offers easy service access and helps cover and protect hydraulic valves from debris and wear.
- Flat body floor and redesigned support structures allow easy serviceability and supports heavy payload capacity.
- Sensors provide full range positions of arm and fork for smooth control.
- McNeilus CODE™ system provides simplified CAN-based controls with outstanding diagnostics and troubleshooting at your fingertips.
- Field -tested packer and arm cylinder sensors are mounted externally for ease of service and maintenance.

PERFORMANCE SPECIFICATIONS (in seconds)*

WORKING RPM	IDLE	1350 RPM
Arm Down	10	10
Arm Up	7	6
Fork Down	5	5
Fork Up	6	6
Packer Extend	N/A	14
Packer Retract	N/A	8
Top Door Open	12	12
Top Door Closed	6	6
Tailgate Open	24	24
Tailgate Closed	24	24

Compaction Force = 119,000 pounds

*Cycle times may vary slightly

ARM ASSEMBLY

Arm Side Plate	1/4 in. grade 80
Arm Construction	Internal reinforcement

FORKS

Fork Construction	1 in. grade 80
-------------------	----------------

HOPPER SPECIFICATIONS

Hopper Capacity	13.2 cu yd
Hopper Floor	3/16 in. AR450
Upper Hopper Sides	0.118 in. 100 XF
Lower Hopper Sides	3/16 in. AR450
Hopper Width	84 in

PACKER/EJECTOR SPECIFICATIONS

Lower Face Plate	1/4 in. AR400
Upper Face Plate	3/16 in. AR200
Packing Panel Floor Tracks	3/16 in. grade 100
Top Wear Strips	1/4 in. AR400
Side Wear Strips	3/8 in. AR400
Bottom Wear Strips	3/8 in. X-Wear

BODY SPECIFICATIONS

Body Floor	3/16 in. AR450
Body Roof	10-gauge AR200
Body Side Walls	1/8 in. AR450

TAILGATE SPECIFICATIONS

Tailgate Rear Wall	1/8 in. AR450
Tailgate Inner Side Walls	1/8 in. AR450
Tailgate Outer Side Walls	0.118 in. 100 XF
Automatic Locking Tailgate	

OPERATIONS

McNeilus CODE™ CAN-based controls offer state of the art technology (smart fuse panel, complete diagnostics, vehicle status messages and pre-trip reminders)

Electronic Proportional Commercial or Residential Joystick

HYDRAULICS

Pump	Dual Kawasaki load-sensing pump
Control Valves	Multi-section stack valve 2610 psi
Oil Reservoir Capacity	50 gallon
Return Filter	5 micron
Suction Strainer	40 mesh stainless steel with magnets

CYLINDERS

Top Door Cylinder	2 in. bore x 1-1/2 in. rod
Excalibre™ Ejector Cylinder	5.5 in. 3-stage x 182 in.
Arm Cylinder	4-1/2 in. bore x 2-1/2 in. rod x 46 in. stroke
Fork Cylinder	3-1/2 in. bore x 2 in. rod x 26 in. stroke
Tailgate Cylinder	2-1/4 in. bore x 1-3/4 in. rod x 35 in. stroke
Tailgate Lock Cylinder	2.5 in. bore x 3 in. rod x 1.0 in. stroke

PAINTING

Packer and components steel shot blasted prior to priming with high solids epoxy primer

Finish: PPG high-performance, high solids acrylic urethane topcoat

McNEILUS WARRANTIES

Contact your McNeilus representative on warranty details.
For more information, go to www.McNeilusGarbageTrucks.com

MERIDIAN™ FRONT LOADER

- Exclusive McNeilus® Excalibre™ cylinders feature a tool steel shaver, field-proven seals and nitrided rods that help manage hydraulic contamination.
- The non-sliding tailgate has a consistent seal and allows easy access to tailgate props.
- Proudly made in the USA.
- McNeilus partners with top equipment dealers across North America to provide best-in-class support and access to service and parts close to home.
- Easy access to quality parts, vehicle support, and online ordering through www.StreetSmartParts.com.

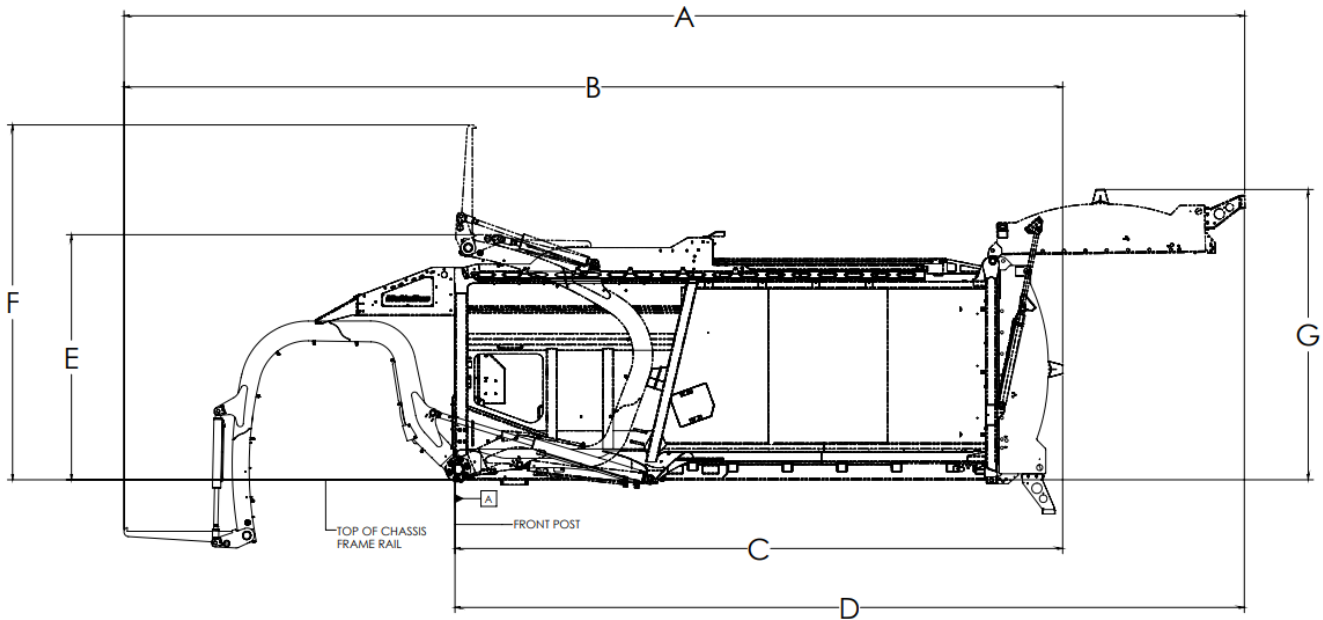

DIMENSIONS

DESCRIPTION	32 YD ³ (24.5M ³)		36 YD ³ (27.5 M ³)		40 YD ³ (30.6 M ³)		43 YD ³ (32.9 M ³)	
(A) *Length: Arms Down, TG Open	499 in	12,675 mm	499 in	12,675 mm	538 in	13,665 mm	538 in	13,665 mm
(B) *Length: Arms Down, TG Closed (with Tailgate CNG)	412 in (428 in)	10,465 mm (10,871 mm)	431 in	10,947 mm	451 in (467 in)	11,455 mm (11,862 mm)	470 in	11,938 mm
(C) Length: Arms Stowed, TG Closed (with Tailgate CNG)	253 in (269 in)	6,426 mm (6,833 mm)	272 in	6,909 mm	292 in (308 in)	7,417 mm (7,823 mm)	311 in	7,899 mm
(D) Length: Arms Stowed, TG Open	340 in	8,636 mm	340 in	8,636 mm	379 in	9,627 mm	379 in	9,627 mm
(E) Height: Arms/Fork Down	118 in	2,997 mm	118 in	2,997 mm	118 in	2,997 mm	118 in	2,997 mm
(F) *Height: Arms Stowed/Forks Up	170 in	4,318 mm	170 in	4,318 mm	170 in	4,318 mm	170 in	4,318 mm
(G) Height: Tailgate Raised (with Tailgate CNG)	139 in (156 in)	3,531 mm (3,962 mm)	159 in	4,039 mm	139 in (156 in)	3,531 mm (3,962 mm)	159 in	4,039 mm
Overall Body Width	102 in	2,591 mm	102 in	2,591 mm	102 in	2,591 mm	102 in	2,591 mm

*Dimensions include a standard 59" fork length. Dimensions will vary with the 67" extended fork option.



We offer a complete line of parts and services for all makes and models.
View and purchase at www.StreetSmartParts.com or call 888.686.7278.



Learn more at www.McNeilusGarbageTrucks.com | StreetSmartParts.com

©2024 McNeilus Truck and Manufacturing. McNeilus, the McNeilus logo, Street Smart Parts, and the Street Smart Parts logo are trademarks of McNeilus Truck and Manufacturing., Dodge Center, MN, USA. All other designated trademarks are the property of their respective owners. Specifications, descriptions and illustrations in this brochure are accurate as shown at the time of publication, but are subject to change without notice. Illustrations may include optional equipment and accessories and may not